



AERONEX® H SERIES GAS PURIFICATION SYSTEM

Continuous ultrapure H₂ gas at a low cost of ownership



continuous ultrapure H₂ gas at a low cost of ownership

Overview

The Aeronex® H Series removes gaseous contaminants such as H₂O, CO, CO₂, O₂ and nonmethane hydrocarbons to sub-ppb levels in hydrogen gas. The systems utilize ambient temperature purification technology, have a low pressure drop and offer a low cost of ownership.

With the Aeronex® H Series systems, all purifiers used in a process are integrated into a single, microprocessor-controlled cabinet with a touch screen interface. Systems use two purifier beds in order to maintain a continuous flow of pure gas. One purifier bed is on line while the other is in regeneration or is ready for use. Contaminants are removed to sub-ppb (part-per-billion) and ppt (part-per-trillion) levels.

All functions such as conditioning and purging are completely automated, requiring minimal user interface and providing maximum reliability and cost of ownership. The system offers improved safety by placing all purifiers in a single location and, because the purifiers are regenerable, there are no environmental concerns.

Panel-mounted subsystems are offered specifically to Original Equipment Manufacturers (OEMs) and are designed for integration into a process tool.

Applications

- Photolithography
- Metallorganic Chemical Vapor Deposition (MOVCD)
- Atomic Layer Deposition (ALD)
- Low Temperature Epitaxy (LTE)
- Other applications that require ultrapure hydrogen gas

Features and Benefits

- Power failure will not damage the purification system
- Complete automatic operation saves time, increases reliability
- Purifies to sub-ppb (part-per-billion) and ppt (part-per-trillion) levels
- Low pressure drop means no changes to inlet pressure are required
- Self-regenerating purifiers provide the lowest cost of ownership
- Ambient temperature purification means lower energy costs and resource conservation
- CE and SEMI® S2 certified
- Start-up service is provided, making it easy to integrate the unit
- The system is designed for easy field maintenance and upgrades
- Available worldwide through Entegris' global infrastructure

Models Available

Model	Description
PGPS4H	Panel-mounted model for OEM use and for applications requiring a flow rate up to 120 SLM
EGPS4H	Enclosed model for use with applications requiring a flow rate up to 120 SLM
EGPS8H	Enclosed model for use with applications requiring a flow rate up to 300 SLM
EGPS12H	Enclosed model for use with applications requiring a flow rate up to 1000 SLM

System Process and Instrumentation Diagram

Models PGPS4H, EGPS4H, EGPS8H

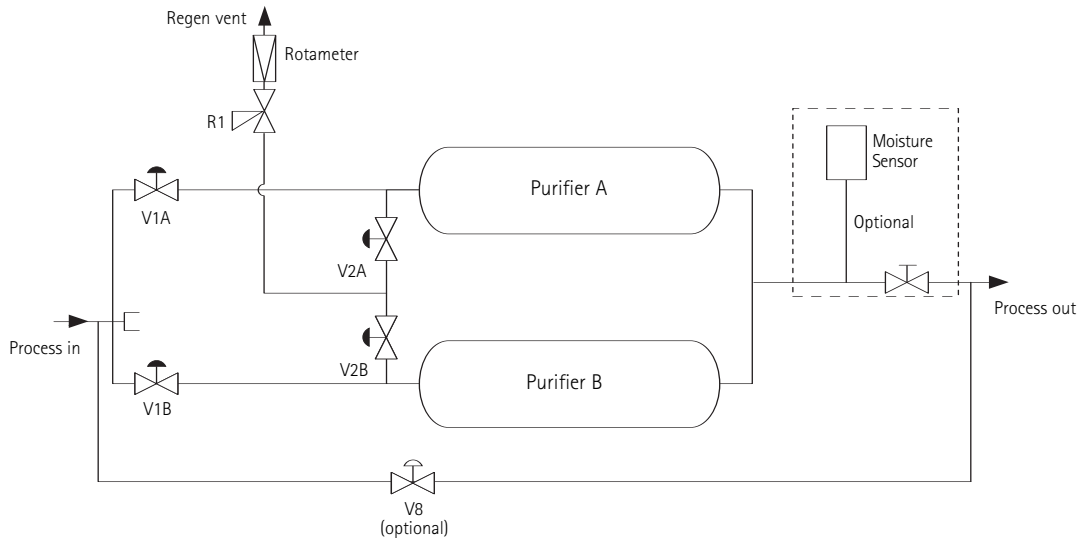

Model EGPS12H

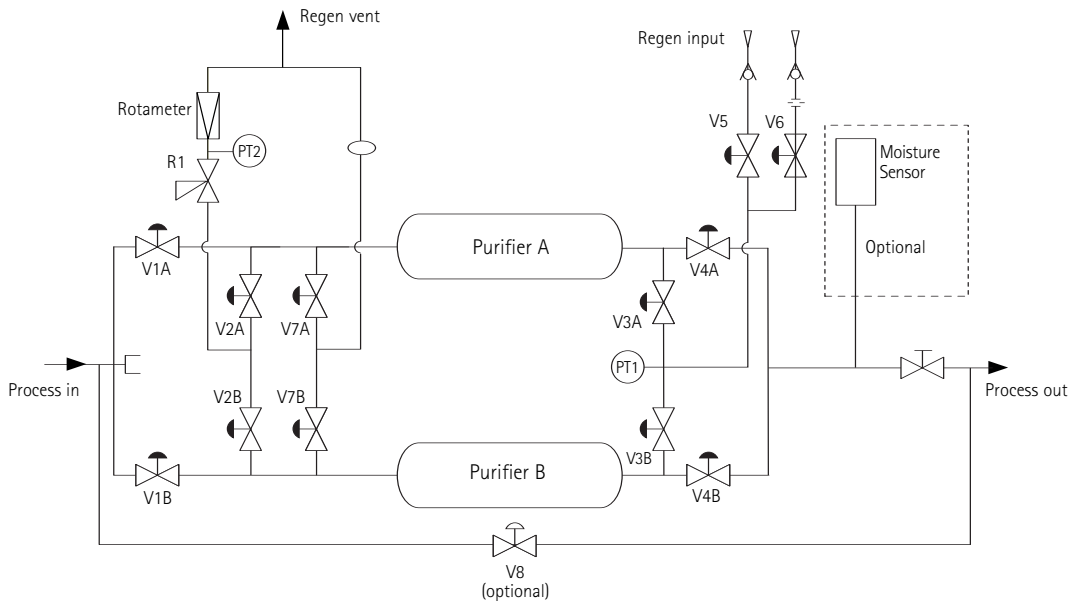

Safety Features

Feature	Description	PGPS4	EGPS4	EGPS8	EGPS12
Circuit breaker	Provides additional electrical protection to the system and includes a lock-out/tag-out.	N/A	Yes	Yes	Yes
Over temperature rise condition	Monitored via thermocouple. Heaters sized to prevent runaway conditions. As a secondary precautionary device, a high-temperature hardware interlock is included on the EGPS4.	Yes	Yes	Yes	Yes
Hydrogen detector	Triggers an EMO alarm and shuts down the system in the event of a gas leak of hydrogen inside system enclosure.	N/A	Yes	Yes	Yes
Rate-of-rise detector	If the detector senses a rapid increase in temperature inside the system enclosure, an EMO alarm will be activated and shut down the system.	N/A	Yes	Yes	Yes
EMO button	When activated, power is removed from the cabinet. The system shuts down. The front panel and controller remain powered.	N/A	Yes	Yes	Yes
Remote EMO	Provides input for remote EMO activation and an output for remote signal of EMO condition.	Yes	Yes	Yes	Yes
Remote alarm	In the event of a minor alarm in the system not requiring an EMO shutdown, the system will send a signal to an external sensing device that alerts the facility of the alarm.	Yes	Yes	Yes	Yes
Visual alarm	In the event of an alarm, a detailed description of the alarm will be displayed in red on systems that include a touch screen. In the event of an alarm on a system with LEDs, a red LED indicator will activate.	Yes	Yes	Yes	Yes
Audible alarm	Alarm conditions result in an audible alarm.	N/A	Yes	Yes	Yes
Static pressure switch/door interlock	Monitors system for adequate static pressure. If enclosure ventilation falls below acceptable levels, an alarm is generated in the system; also serves as a door interlock to prevent the system from being used while the door is opened.	N/A	Yes	Yes	Yes
Isolated electrical enclosure	Electronics are physically isolated from the main purifier cabinet in an attached electrical enclosure in situations where high-voltage lines are near potentially flammable gas. Low-voltage components located inside the enclosure are SELV (safety extra low voltage).	N/A	Yes	Yes	Yes
Single or dual contained plumbing interface	Allows end user to use either single or dual contained plumbing for installation.	Yes	Yes	Yes	Yes

Product Specifications

Model	PGPS4	EGPS4	EGPS8	EGPS12
Gases purified	H ₂			
Media type	Inorganic			
Contaminants removed	H ₂ O, CO, CO ₂ , O ₂ and nonmethane hydrocarbons			
Outlet purity	<1 part-per-billion (ppb)*			
Operating pressure range	515–1825 kPa (60–250 PSIG)			1136 kPa (60–150 PSIG)
Pressure drop	<15 PSI @ 120 PSIG inlet and max rated flow			<17 PSI @ 90 PSIG and max rated flow
Maximum flow rate	120 SLM		300 SLM	1000 SLM
Gas operating temperature	–40°C to +60°C (–40°F to +150°F)			
Outlet filtration	0.003 micron @ 99.9999999% efficiency			
Leak rating	1 × 10 ⁻⁹ atm cc/sec.			

*Outlet purity is significantly lower for some contaminants. Test data available upon request.

Facility Specifications

Specifications		PGPS4	EGPS4	EGPS8	EGPS12
Process gas input	Mechanical connection	1/4" face seal	1/4" tube stub	1/2" tube stub	3/4" tube stub
Process gas output	Mechanical connection	1/4" face seal	1/4" tube stub	1/2" tube stub	3/4" tube stub
Ventilation	Mechanical connection	N/A	4" duct		
	Exhaust flow	N/A	50 CFM	100 CFM	65 CFM
Power requirements	Mechanical connection	Standard terminal			
	Power requirements	200–240 VAC			
	Power consumption	50W at idle and process mode; 300W during regen		50W at idle and process mode; 800W during regen	50W at idle and process mode; 1000W during regen
Regeneration	Max regen frequency	3 days (May be configured per customer inlet gas purity)			
	Regen duration	48 hours			
Regen gas input 1	Gas	N/A			N ₂ 515–929 kPa (60–120 PSIG)
	Mechanical connection	N/A			1/4" tube stub
Regen gas input 2	Gas	N/A			H ₂ 515–929 kPa (60–120 PSIG)
	Mechanical connection	N/A			1/4" tube stub
Regen gas output	Pressure	Atmospheric			
	Mechanical connection	1/4" tube stub			
Instrument air	Gas and pressure	CDA or N ₂ @ 653–791 kPa (80–100 PSIG)			
	Mechanical connection	1/4" compression fitting			
Physical requirements	Mounting	Wall		Floor	
	Shipping weight	32 kg (70 lbs)	39 kg (85 lbs)	113 kg (250 lbs)	205 kg (450 lbs)
	Operating conditions	15°–40°C indoor (60°–104°F indoor)			
	Humidity	10–90% RH noncondensing			

It is the customer's responsibility to ensure that the equipment is installed according to local building code requirements.

Model PGPS4

Dimensional Information

Front view

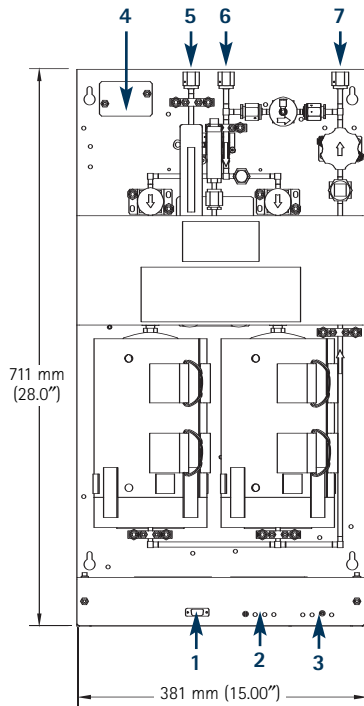

Side view

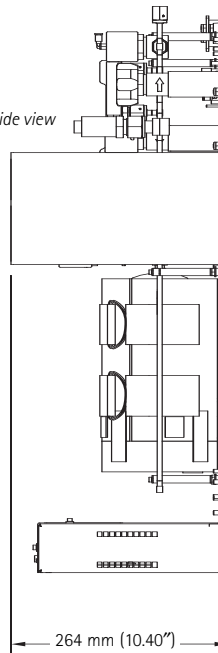

Top view

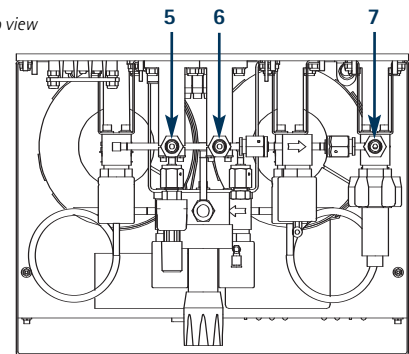

System Connections

1	Communications port	For user interface via PC
2	LED indicators	For main power, bed on line, bed regen, heaters and alarms
3	Start	Used to begin system operations and to clear alarms
4	A/C terminal block	Power connection
5	Gas exhaust/regen vent	Exhausts regen gas
6	Process gas input	Inlet gas (not purified)
7	Process gas output	Outlet gas (purified)

Panel Information

This equipment is not enclosed. It is the user's responsibility to ensure that it is installed in compliance with local safety requirements for gas equipment. The PGPS4 is designed using SEMI® S2 guidelines (for gas equipment enclosures). Because it is a subsystem, it must be certified with the final product in which it is used.

Model EGPS4

Dimensional Information

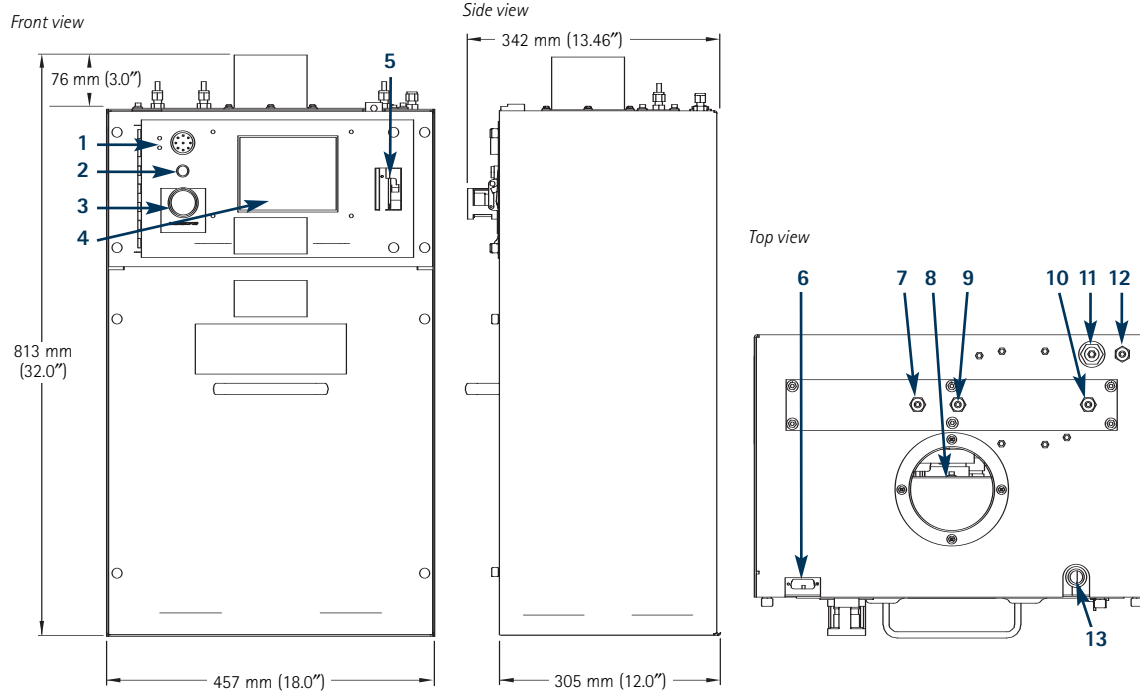

System Connections

1	Audible alarm	Audible warning informs of alarm condition
2	Start	Used to begin system operations and to clear alarms
3	EMO	When activated, power is removed from the cabinet. The system shuts down. Front panel and controller remain powered.
4	Touch screen	For system status and interface
5	Circuit breaker	Provides additional electrical protection to the system and in some models also acts as an ON/OFF switch for the system
6	Remote alarm interface	Allows for remote alarm input and output with female 15 pin DB connector
7	Regen gas vent	Exhausts regen gas
8	Exhaust vent	Allows ventilation
9	Process gas input	Inlet gas (not purified)
10	Process gas output	Outlet gas (purified)
11	Reference	Atmospheric reference for the internal enclosure flow sensor
12	Instrument air	Supplies gas to the air-operated control valves
13	A/C power input	Power connection

Enclosure Information

The ventilated enclosure is designed for indoor applications only. The enclosure has mounting locations on the back surface. The front panel is removable.

Model EGPS8

Dimensional Information

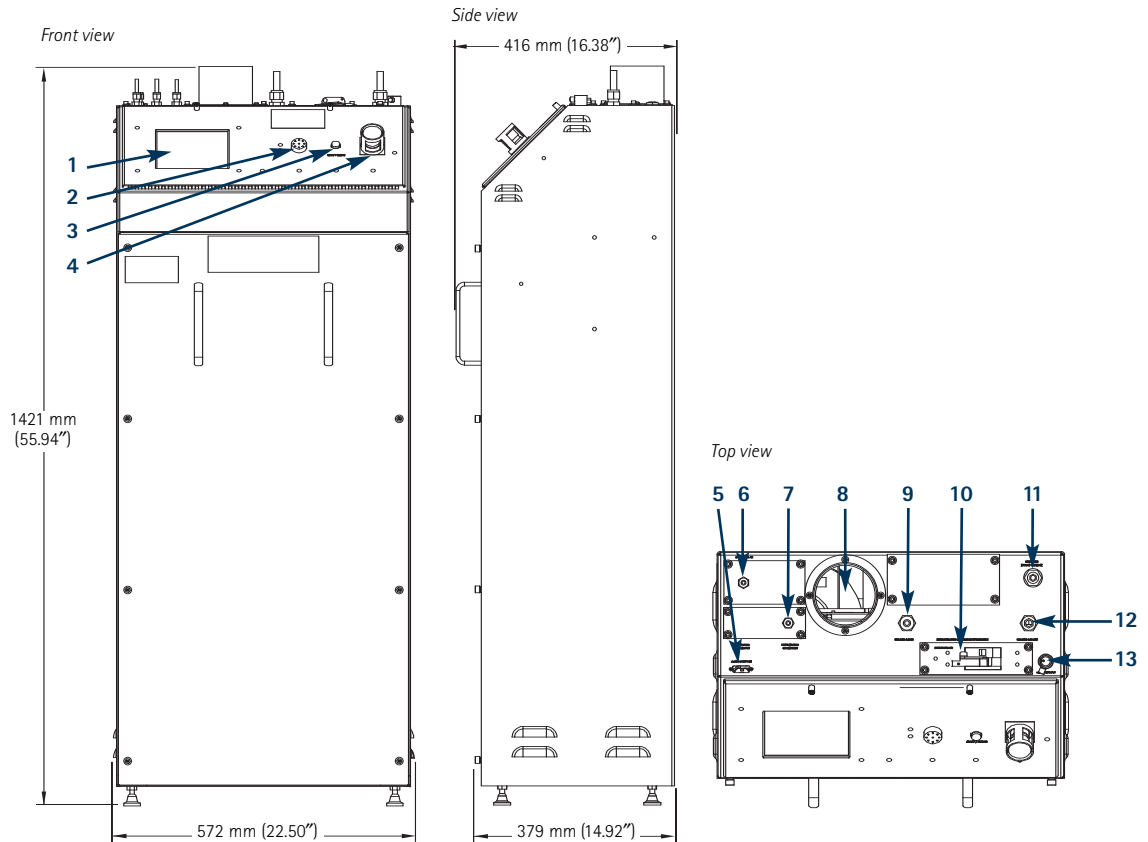

System Connections

1	Touch screen	For system status and interface
2	Audible alarm	Audible warning informs of alarm condition
3	Start	Used to begin system operations and to clear alarms
4	EMO	When activated, power is removed from the cabinet. The system shuts down. Front panel and controller remain powered.
5	Remote alarm interface	Allows for remote alarm input and output with female 15 pin DB connector
6	Instrument air	Supplies gas to the air-operated control valves
7	Regen gas vent	Exhaust regen gas
8	Exhaust vent	Allows ventilation
9	Process gas input	Inlet gas (not purified)
10	Circuit breaker	Provides additional electrical protection to the system and in some models also acts as an ON/OFF switch for the system.
11	Reference	Atmospheric reference for the internal enclosure flow sensor
12	Process gas output	Outlet gas (purified)
13	A/C power input	Power connection

Enclosure Information

The ventilated enclosure is designed for indoor applications only. The enclosure has bolt down locations on the bottom surface. The front panel is removable.

Model EGPS12

Dimensional Information

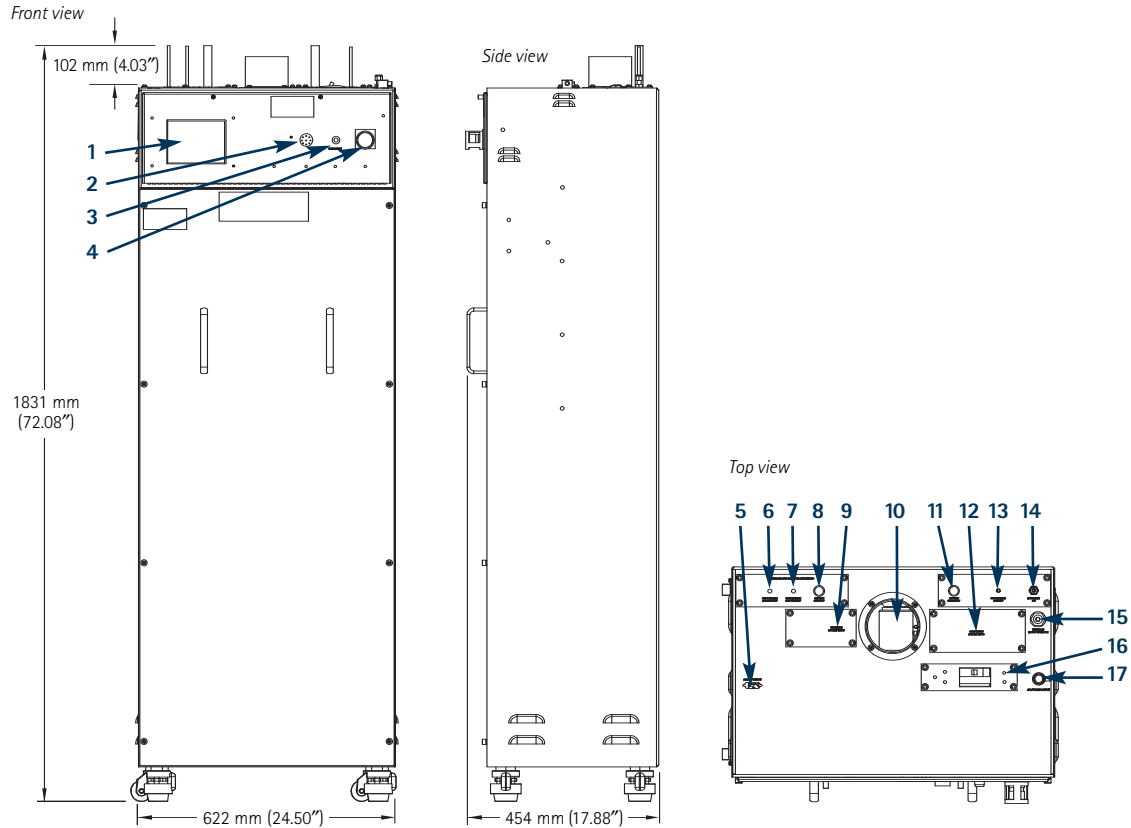

System Connections

1	Touch screen	For system status and interface
2	Audible alarm	Audible warning informs of alarm condition
3	Start	Used to begin system operations and to clear alarms
4	EMO	When activated, power is removed from the cabinet. The system shuts down. Front panel and controller remain powered.
5	Remote alarm interface	Allows for remote alarm input and output with female 15 pin DB connector
6	Regen gas input 1	Nitrogen input
7	Regen gas input 2	Hydrogen input
8	Process gas input	Inert gas (not purified)
9	Fire sensor located below cover	
10	Exhaust vent	Allows ventilation
11	Process gas output	Outlet gas (purified)
12	Gas monitor located below cover	
13	Regen gas vent	Exhausts regen gas
14	Instrument air	Supplies gas to the air-operated control valves
15	Reference	Atmospheric reference for the internal enclosure flow sensor
16	Circuit breaker	Provides additional electrical protection to the system and in some models also acts as an ON/OFF switch for the system
17	A/C power input	Power connection

Enclosure Information

The ventilated enclosure is designed for indoor applications only. The enclosure has bolt down locations on the bottom surface. The front panel is removable.

Options

Available Options	Letter (Designator)	PGPS4	EGPS4	EGPS8	EGPS12
Automatic bypass manifold	A	Yes	Yes	Yes	Yes
Manual bypass manifold	M	Yes	N/A	Yes	Yes
Moisture indicator	T	Yes	Yes	Yes	Yes

Ordering Information

Part Number

PGPS4 Panel-mounted model for OEM use and applications requiring a flow rate up to 120 SLM	EGPS4 Use with applications requiring a flow rate up to 120 SLM	EGPS8 Use with applications requiring a flow rate up to 300 SLM	EGPS12 Use with applications requiring a flow rate up to 1000 SLM
PGPS4H	EGPS4H	EGPS8H	EGPS12H
PGPS4HA	EGPS4HA	EGPS8HA	EGPS12HA
PGPS4HAT	EGPS4HAT	EGPS8HAT	EGPS12HAT
PGPS4HM	EGPS4HT	EGPS8HM	EGPS12HM
PGPS4HMT		EGPS8HMT	EGPS12HMT
PGPS4HT		EGPS8HT	EGPS12HT

Part Number	Automatic Bypass Manifold	Manual Bypass Manifold	Moisture Indicator
PGPS4H			
PGPS4HA	Yes		
PGPS4HAT	Yes		Yes
PGPS4HM		Yes	
PGPS4HMT		Yes	Yes
PGPS4HT			Yes
EGPS4H			
EGPS4HA	Yes		
EGPS4HAT	Yes		Yes
EGPSHT			Yes

Part Number	Automatic Bypass Manifold	Manual Bypass Manifold	Moisture Indicator
EGPS8H			
EGPS8HA	Yes		
EGPS8HAT	Yes		Yes
EGPS8HM		Yes	
EGPS8HMT		Yes	Yes
EGPS8HT			Yes
EGPS12H			
EGPS12HA	Yes		
EGPS12HAT	Yes		Yes
EGPS12HM		Yes	
EGPS12HMT		Yes	Yes
EGPS12HT			Yes

Specifications are subject to change.
Please verify prior to order.



For More Information

Please call your Regional Customer Service Center today to learn what Entegris can do for you. Visit www.entegris.com and select “Regional Customer Service Centers” for the center nearest you.

Terms and Conditions of Sale

All purchases are subject to Entegris’ “Terms and Conditions of Sale.” To view and print this information, visit Entegris’ website at www.entegris.com and select the Legal Notices link from the footer found on the home page.

Entegris® and Aeronex® are registered trademarks of Entegris, Inc.
SEMI® is a registered trademark of Semiconductor Equipment and Materials International.
U.S. Patent 6,361,696

ENTEGRIS, INC.

Corporate Headquarters / 3500 Lyman Boulevard / Chaska, Minnesota 55318 USA
Customer Service Tel. 952-556-4181 / Customer Service Fax 952-556-8022
www.entegris.com